

# Elliott Turbine Generator Sets

## ■ STEAM TURBINE GENERATORS FROM ELLIOTT

Elliott steam turbine generator (STG) sets for power generation offer the features, functions and benefits essential to support today's commercial energy requirements. Elliott STGs are available in a wide range of power offerings, from 50 kW to 50 MW, and with synchronous and induction generator options. Elliott delivers complete design packages including the steam turbine, speed-reducing gear, generator, lube system, integrated control system, baseplates, commissioning services, operator and maintenance training, and long-term maintenance programs. With more than 100 years of engineering experience, Elliott has the expertise to create an STG tailored to your specific requirements.



## ■ EFFICIENT RELIABLE POWER

An Elliott STG is an efficient, cost-effective means of producing renewable electric power from the excess thermal energy in a steam system or from an alternative fuel source such as biomass. Depending upon local utility cost models, an Elliott STG configured to your specific requirements in most cases can provide payback on your capital expenditure in three years or less.

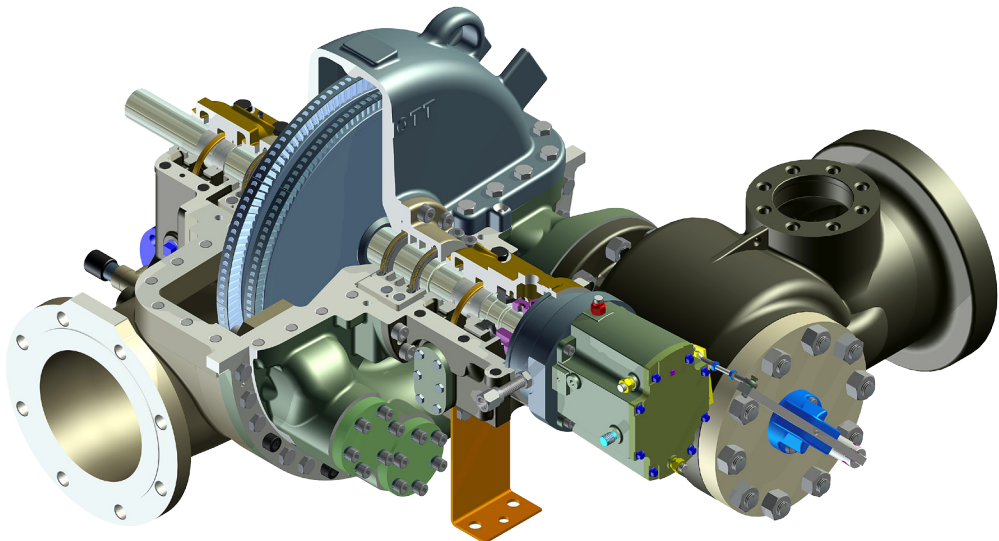

## ■ THE RIGHT MIX

With output to 10 MW, Elliott's highly reliable, single valve YR turbines are well-suited to geared, synchronous or induction turbine generator applications. More than 35,000 Elliott YR turbines have been sold around the world.

Elliott's larger, multivalve turbine can be configured to meet the most demanding applications up to 50 MW, including extraction and induction.

Cost-effective co-generation of electricity begins with "the right mix." The right mix starts with a predictable steam supply. The other component of the mix is a known electrical load and whether there is a need for steam for other processes. With alternating seasonal demand for heating and air conditioning, and consistent staffing levels, many institutions such as universities, medical centers, correctional institutions and corporate campuses fit this profile.

The prevalent use of steam in industrial processes identifies those plants as excellent candidates for electrical co-generation. Steam pressures and quantities often exceed process requirements. With an Elliott STG, excess thermal energy can be cost-effectively converted into electricity rather than wasted. Industries such as lumber, sugar, and food processing burn waste material for low-cost steam production. In these situations, an Elliott STG can pay for itself in less than one year.

Elliott STGs have been successfully integrated into many industrial applications including:

- ◆ Combined Heat & Power
- ◆ Waste-to-Energy/Biomass
- ◆ Waste Heat Recovery
- ◆ Geothermal

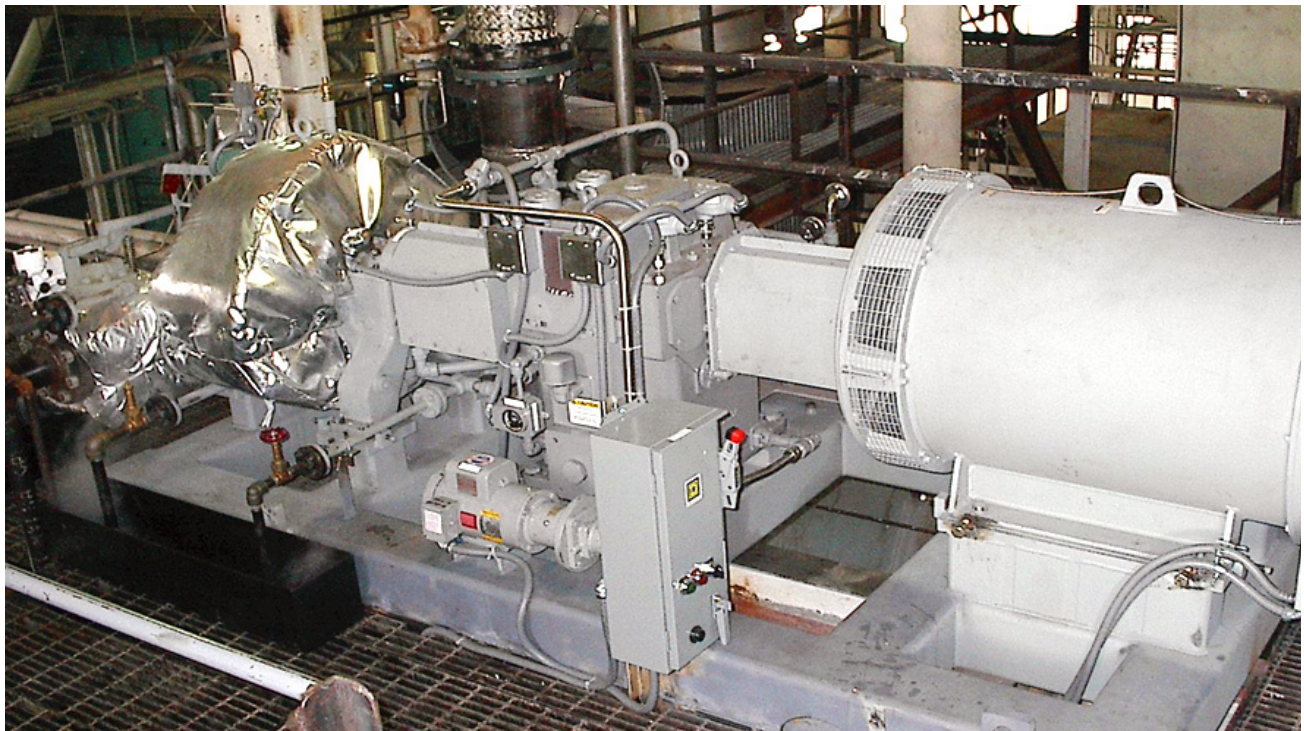

## ■ POWER TO MATCH YOUR NEEDS

Elliott's focus with every customer is to select the right turbine generator to do the job. Tens of thousands of flexible, reliable Elliott steam turbines are driving generators, pumps, compressors, fans, blowers and many other industrial plant applications. Our steam turbine generator configurations match a wide range of application and power requirements.

### Single-valve, single stage:

- ◆ Back pressure
- ◆ Condensing
- ◆ Ratings up to 2,500 HP
- ◆ 50 kW to 3 MW
- ◆ 900 psig (63.3 kg/cm<sup>2</sup>)\*
- ◆ 900° F (482° C)\*

### Multivalve multistage:

- ◆ Back pressure
- ◆ Condensing
- ◆ 3 MW to 50 MW
- ◆ Extraction back pressure
- ◆ Extraction Condensing
- ◆ Induction
- ◆ 2,000 psig (140.kg/cm<sup>2</sup>)\*

### Single-valve multistage:

- ◆ Back pressure
- ◆ Condensing
- ◆ 1 MW to 10 MW
- ◆ Ratings up to 10,000 HP
- ◆ 900 psig (63.3 kg/cm<sup>2</sup>)\*
- ◆ 900° F (482° C)\*

*\* Design ratings: All turbines can be optimized to meet specific steam conditions.*

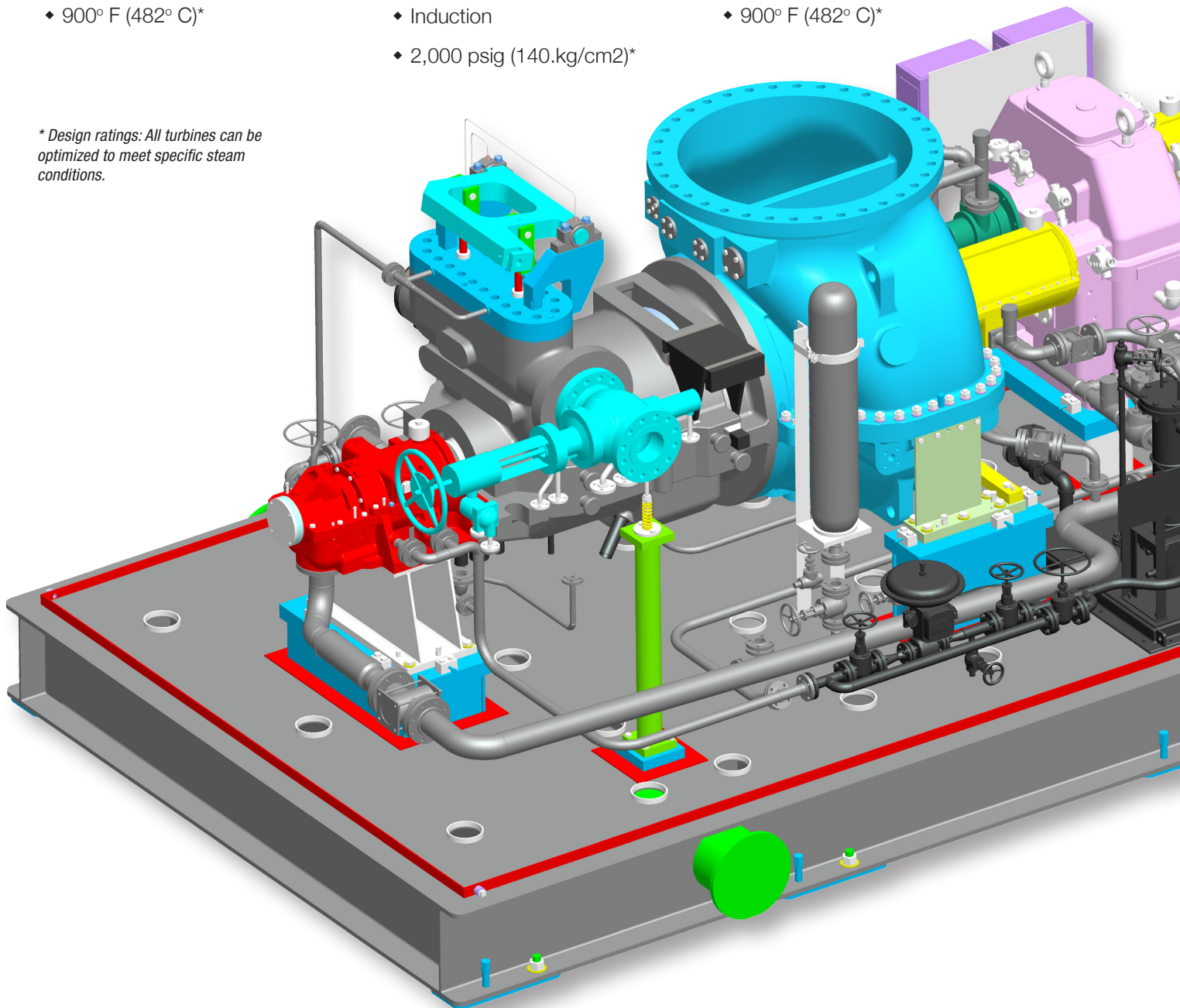

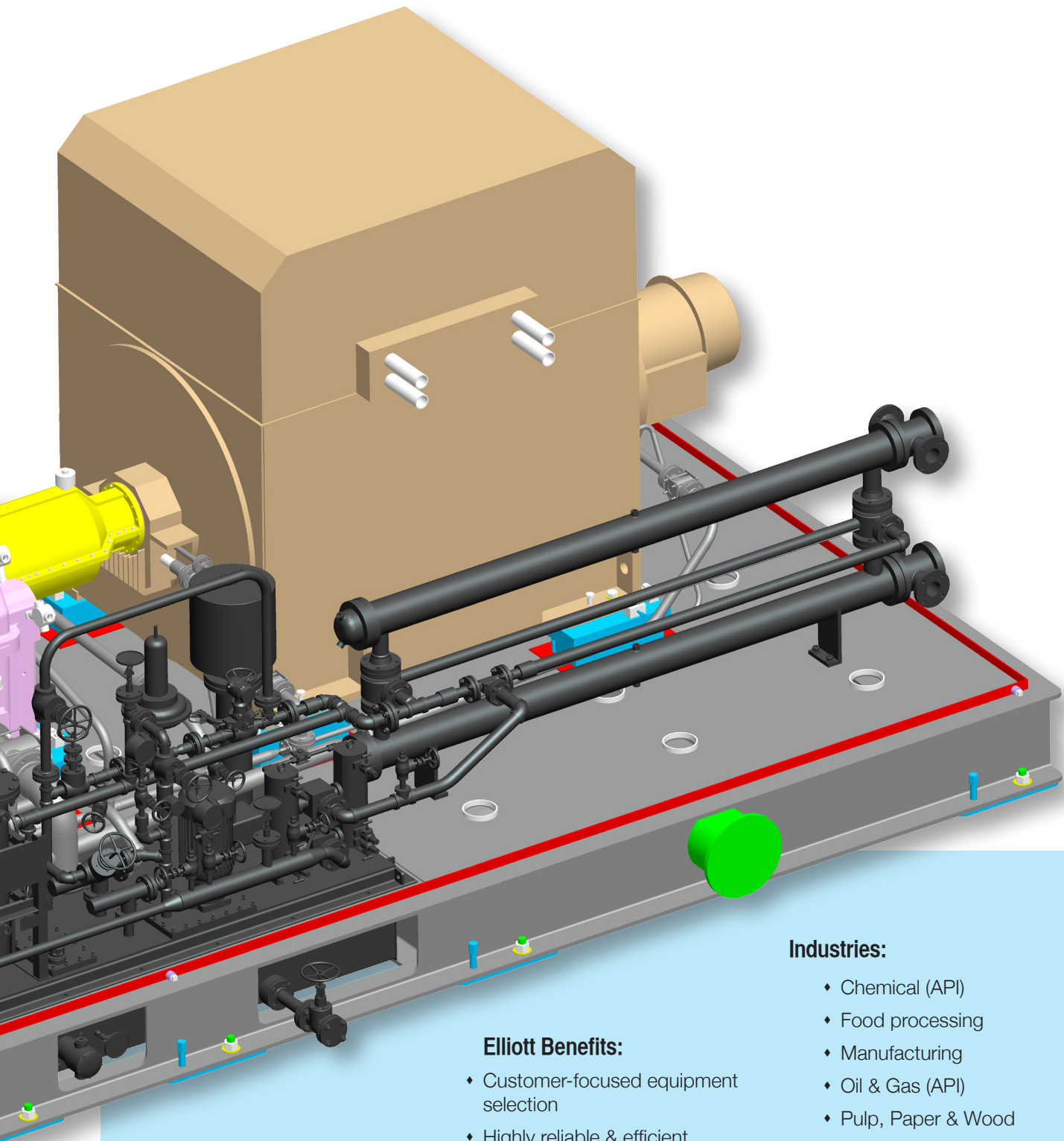

#### Applications:

- ♦ Combined Heat & Power
- ♦ Waste-to-Energy
- ♦ Waste Heat Recovery
- ♦ Geothermal

#### Elliott Benefits:

- ♦ Customer-focused equipment selection
- ♦ Highly reliable & efficient
- ♦ Consolidated equipment footprint
- ♦ Packaging Solutions
- ♦ Comprehensive global service

#### Industries:

- ♦ Chemical (API)
- ♦ Food processing
- ♦ Manufacturing
- ♦ Oil & Gas (API)
- ♦ Pulp, Paper & Wood
- ♦ Pharmaceuticals
- ♦ Steel
- ♦ Sugar
- ♦ Palm oil

## ■ FULLY INTEGRATED CONTROL SYSTEMS

Elliott offers sophisticated, flexible, easy-to-use STG control systems. Operators can manage their systems in any of several modes such as island, black start, tandem, paralleled generation or grid interfaced. These systems also can be configured to communicate with all of the most common control interfaces in use today.

- ◆ PLC-based monitoring: vibration, RTD, pump, pre-alarms, trip system
- ◆ Touch-screen interface (HMI) for easy, accurate display and control
- ◆ Auto and manual synchronizing with synch check protection relay
- ◆ Independent overspeed trip protection
- ◆ Multifunction generator protection relay
- ◆ Excitation control (automatic voltage regulator)
- ◆ Network communication and remote access capabilities
- ◆ Custom tailored instrumentation to meet the plant's needs



## ■ PACKAGED SOLUTIONS

An Elliott steam turbine generator set is a completely integrated package. Elliott engineers design each unit to ensure trouble-free installation, start-up and operation. We are able to reduce both installation and maintenance costs by consolidating the equipment footprint, minimizing on-site alignment, and tightly integrating all connections.

A typical synchronous steam turbine generator package includes a steam turbine, gear, couplings, generator, baseplate, integrated control systems and lubrication console. Lower-cost induction generator packages eliminate the need for reduction gears for grid-dependent applications. Elliott also can provide auxiliary systems such as electrical switch gears and condensers.



## GLOBAL SERVICE AND SUPPORT

Elliott offers comprehensive service and support for all types of turbomachinery regardless of the original manufacturer. Our experienced engineers, metallurgists, technicians, welders and mechanics have the expertise and experience to keep equipment performance high and maintenance costs low.

Elliott's global service network is ISO 9001:2008 certified and provides installation, maintenance, repair, overhauls, parts, rerates, modifications and training, 24 hours a day, 7 days a week. Supported by our service centers throughout the world, Elliott's field service teams are recognized for their hands-on experience with comprehensive overhauls; project management; resource planning; subcontractor control; installation and commissioning and on-site repair. Elliott Technical Services provides practical, timely and cost-effective solutions for complex turbomachinery problems. Rerates and modifications by Elliott Engineered Solutions enhance operating efficiency and extend the life of rotating equipment from any manufacturer.

Elliott is fully compliant with all relevant industry standards including API, ANSI, APO, CRN, CSA, and CE/PED. We are accredited by the American Society of Mechanical Engineers (ASME), holding both the U and the R Boiler and Pressure Vessel (BPV) certifications, and we adhere to the principals of the American Society of Nondestructive Testing (ASNT) and are SNT-TC 1A compliant.

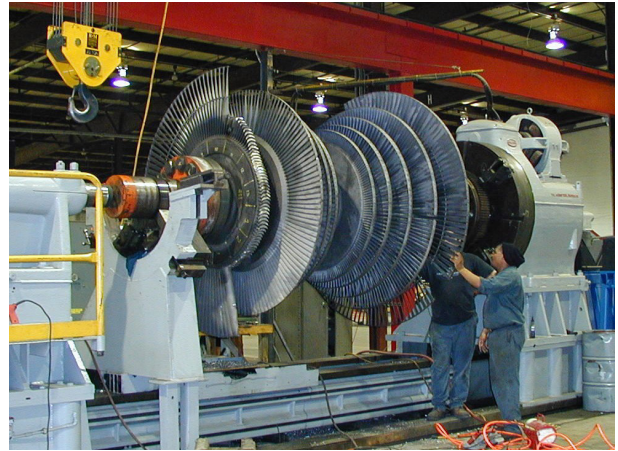



Elliott Group is a global leader in the design, manufacture and service of technically advanced centrifugal compressors, steam turbines, power recover expanders and axial compressors used in the petrochemical, refining, oil & gas and process industries, as well as in power applications. Elliott Group is a wholly owned subsidiary of Ebara Corporation, a major industrial conglomerate headquartered in Tokyo, Japan.



901 North Fourth Street  
Jeannette, PA 15644-1473  
Telephone: 724-527-2811  
Fax: 724-600-8442  
Email: [info@elliott-turbo.com](mailto:info@elliott-turbo.com)

[www.elliott-turbo.com](http://www.elliott-turbo.com)

T H E W O R L D T U R N S T O E L L I O T T

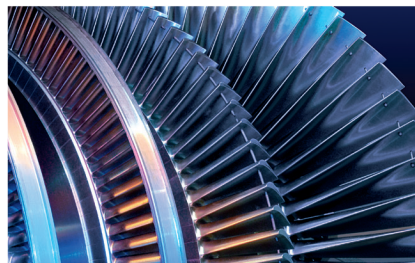

C O M P R E S S O R S ■ T U R B I N E S ■ G L O B A L S E R V I C E